

*TB 9-6625-1014-35

DEPARTMENT OF THE ARMY TECHNICAL BULLETIN

CALIBRATION PROCEDURE FOR CAPACITANCE, INDUCTANCE, AND RESISTANCE TEST SET AN/URM-90 (ZM-30/U) AND UNIVERSAL IMPEDANCE BRIDGE, ELECTRO-SCIENTIFIC INDUSTRIES (ESI), MODEL 250DE

Headquarters Department of the Army, Washington, DC
4 August 2005

Distribution Statement A: Approved for public release; distribution is unlimited.

REPORTING OF ERRORS AND RECOMMENDING IMPROVEMENTS

You can improve this manual. If you find any mistakes or if you know of a way to improve these procedures, please let us know. Mail your letter or DA Form 2028 (Recommended Changes to Publications and Blank Forms) directly to Commander, US Army Aviation and Missile Command, AMSAM-MMC-MA-NP, Redstone Arsenal, AL 35898-5000. A reply will be furnished to you. You may also provide DA Form 2028 information to AMCOM via e-mail, fax, or the World Wide Web. Our FAX number is: DSN 788-6546 or Commercial 256-842-6546. Our e-mail address is: 2028@redstone.army.mil. Instructions for sending an electronic 2028 may be found at the back of this manual. For the World Wide Web, use: <https://amcom2028.redstone.army.mil>.

SECTION		Paragraph	Page
I.	IDENTIFICATION AND DESCRIPTION		
	Test instrument identification	1	2
	Forms, records, and reports.....	2	2
	Calibration description	3	2
II.	EQUIPMENT REQUIREMENTS		
	Equipment required.....	4	3
	Accessories required.....	5	3
III.	CALIBRATION PROCESS FOR AN/URM-90 (ZM-30/U)		
	Preliminary instructions.....	6	4
	Equipment setup	7	4
	LRC dials	8	5
	LRC dial multiplier	9	6

*This bulletin supersedes TB 9-6625-1014-35, 20 June 1987 including all changes.

	Paragraph	Page
QX1 rheostat.....	10	7
Oscillator.....	11	8
Capacitance	12	9
Final procedure	13	10
IV. CALIBRATION PROCEDURE FOR ESI, MODEL 250DE		
Preliminary instructions.....	14	10
Equipment setup	15	10
LRC dials	16	11
QX1 rheostat.....	17	12
Resistance	18	13
Oscillator.....	19	14
Capacitance	20	14
Dissipation	21	14
Final procedure	22	16

**SECTION I
IDENTIFICATION AND DESCRIPTION**

1. Test Instrument Identification. This bulletin provides instructions for the calibration of Capacitance, Inductance, and Resistance Test Set AN/URM-90 (ZM-30/U) and Universal Impedance Bridge, Electro-Scientific Industries (ESI), Model 250DE. The manufacturer's manual was used as prime data source in compiling these instructions. The equipment being calibrated will be referred to as the TI (test instrument) throughout this bulletin.

a. Model Variations. Variations among models are described in text.

b. Time and Technique. The time required for this calibration is approximately 12 hours, using the dc and low frequency technique.

2. Forms, Records, and Reports

a. Forms, records, and reports required for calibration personnel at all levels are prescribed by TB 750-25.

b. Adjustments to be reported are designated (R) at the end of the sentence in which they appear. When adjustments are in tables, the (R) follows the designated adjustments. Report only those adjustments made and designated with (R).

3. Calibration Description. TI parameters and performance specifications which pertain to this calibration are listed in table 1.

Table 1. Calibration Description

Test instrument parameters	Performance specifications
AN/URM-90 (ZM-30/U)	
LRC resistance	Range: 0.1 mΩ to 11 MΩ Accuracy: ± (0.35% + 1 dial div) on 0.1 Ω range ± (0.2% + 1 dial div) on 100 kΩ range ± (0.15% + 1 dial div) on all other ranges
Frequency	Range: 1000 Hz Accuracy: ± 1%
Capacitance	Range: 0.1 pF to 100 μF Accuracy: ± (0.5% + dial div) from 100 pF to 100 μF ± 2% above 100 μF; ±2 pF below 100 pF
ESI MODEL 250DE	
LRC resistance	Range: 0 to 12 MΩ Accuracy: ± (0.1% + 1 dial div)
QX1 rheostat	Range: 3184 to 15.920 Ω Accuracy: ± (1% + 1 dial div)
Frequency	Range: 1000 Hz Accuracy: ± 1%
Capacitance	Range: 0 to 1200 μF Accuracy: ± (0.2% + 1 dial div + 1% X dissipation factor)
Dissipation factor	Range: 0 to 1.05 Accuracy: ± (1% + 1 dial div)

SECTION II EQUIPMENT REQUIREMENTS

4. Equipment Required. Table 2 identifies the specific equipment to be used in this calibration procedure. This equipment is issued with Secondary Transfer Calibration Standards Set AN/GSM-286, AN/GSM-287, or AN/GSM-705. Alternate items may be used by the calibrating activity. The items selected must be verified to perform satisfactorily prior to use and must bear evidence of current calibration. The equipment must meet or exceed the minimum use specifications listed in table 2. The accuracies listed in table 2 provide a four-to-one ratio between the standard and TI. Where the four-to-one ratio cannot be met, the actual accuracy of the equipment selected is shown in parenthesis.

5. Accessories Required. The accessories required for this calibration are common usage accessories, issued as indicated in paragraph 4 above, and are not listed in this calibration procedure.

Table 2. Minimum Specifications of Equipment Required

Common name	Minimum use specifications	Manufacturer and model (part number)
AUTOTRANSFORMER	Range: 105 to 125 V ac Accuracy: ± 1%	Ridge, Model 9020A (9020A)
CAPACITANCE STANDARD	Range: 0.1μF Accuracy: ± 0.075%	Arco Electronic, Model SS-32 (7907233)

Table 2. Minimum Specifications of Equipment Required - Continued

Common name	Minimum use specifications	Manufacturer and model (part number)
MULTIMETER	Range: 0 to 20 V ac Frequency: 1kHz Accuracy: ± 3%	Fluke, Model 8840A/AF05 (AN/GSM-64D)
RESISTANCE MEASUREMENT SYSTEM ^{1 2}	Range: Dc detector 0 to 10 V Bridge: 0 to 1.2 MΩ Accuracy: ± 0.025%	ESI, Model 801 (7912151-2) w/ESI, Model 230B (7912150-2)
RESISTANCE STANDARD	Range: 0 to 1.2 MΩ Accuracy: ± 0.03%	Biddle-Gray, Model 71-631 (7910328)

¹Dc detector sensitivity 5μV.

²Limited deployed.

SECTION III CALIBRATION PROCESS FOR AN/URM-90 (ZM-30/U)

6. Preliminary Instructions

a. The instructions outlined in paragraphs 6 and 7 are preparatory to the calibration process. Personnel should become familiar with the entire bulletin before beginning the calibration.

b. Items of equipment used in this procedure are referenced within the text by common name as listed in table 2.

c. Unless otherwise specified, verify the result of each test and, whenever the test requirement is not met, take corrective action before continuing with the calibration. Adjustments required to calibrate the TI are included in this procedure. Additional maintenance information is contained in the manufacturer's manual for this TI.

d. Unless otherwise specified, all controls and control settings refer to the TI.

7. Equipment Setup

WARNING

HIGH VOLTAGE is used or exposed during the performance of this calibration. DEATH ON CONTACT may result if personnel fail to observe safety precautions. REDUCE OUTPUT(S) to minimum after each step within the performance check where applicable.

a. Remove protective covers from TI.

b. Connect TI to autotransformer.

c. Connect autotransformer to a 115 V ac source and adjust for a 115 V output.

d. Loosen locking screw one full turn (located on right hand side of TI galvanometer zero - adjustment knob).

- e. Adjust galvanometer zero adjustment control for zero indication.
- f. Tighten screw loosened in **d** above.
- g. Short **EXT D-Q** binding posts with a bus bar or jumper.

8. LRC Dials

a. Performance Check

- (1) Position controls as listed in (a) through (d) below:
 - (a) **DETECTOR** switch to **METER**.
 - (b) **LRC DIAL MULTIPLIER** switch to **1KΩ**.
 - (c) **CIRCUIT SELECTOR** switch to **RX1**.
 - (d) **LRC** outer dial to **1**; **LRC** middle and inner dials to **0**.
- (2) Connect resistance standard to **L-R** binding posts of TI.
- (3) Adjust resistance standard to 1000 Ω and set **TI GENERATOR** switch to **DC HIGH**.
- (4) Adjust resistance standard for a null on galvanometer. Set **METER SHUNT** switch for fine adjustment. Resistance standard will indicate between 997.5 and 1002.5 Ω.
- (5) Repeat technique of (3) and (4) above for **LRC** dial settings and indications listed in table 3. Resistance standard will indicate within limits specified.

b. Adjustments. No adjustments can be made.

Table 3. **LRC** Dial Check

Test instrument LRC dial settings			Resistance standard indications (Ω)	
Outer	Middle	Inner	Min	Max
2	0	0	1996	2004
3	0	0	2994.5	3005.5
4	0	0	3993	4007
5	0	0	4991.5	5008.5
5	1	0	5091.35	5108.65
5	1	1	5101.34	5118.67
5	1	2	5111.32	5128.68
5	1	3	5121.31	5138.70
5	1	4	5131.29	5148.71
5	1	5	5141.28	5158.73
5	1	6	5151.26	5168.74
5	1	7	5161.25	5178.76
5	1	8	5171.23	5188.77
5	1	9	5181.22	5198.79
5	2	0	5191.20	5208.80
5	3	0	5291.05	5308.95
5	4	0	5390.90	5409.10
5	5	0	5490.75	5509.25
5	6	0	5590.60	5609.40
5	7	0	5690.45	5709.55
5	8	0	5790.30	5809.70
5	9	0	5890.15	5909.85

Table 3. LRC Dial Check

Test instrument LRC dial settings			Resistance standard indications (Ω)	
Outer	Middle	Inner	Min	Max
6	0	0	5990	6010
7	0	0	6988.5	7011.5
8	0	0	7987	8013
9	0	0	8985.5	9014.5
10	0	0	9984	10,016

9. LRC Dial Multiplier

a. Performance Check

(1) Connect **EXT DET** terminals to **INPUT** terminals of dc detector (part of resistance measurement system). Set **DETECTOR** switch to **EXTERNAL**.

(2) Connect resistance standard to **L-R LO** binding posts.

(3) Adjust **LRC** dials to **0.05** and set **LRC DIAL MULTIPLIER** switch to **R-0.1 Ω** .

(4) Adjust resistance standard for 0 Ω .

(5) Measure resistance of leads utilized in step (2) above, using TI and dc detector. Record TI indication.

(6) Adjust resistance standard for 1 Ω .

(7) Adjust **LRC** dial for 0 indication on null meter. Record dial indication.

(8) Subtract value recorded in (5) above from value recorded in (7) above. Difference will be between 0.9964 and 1.0036 Ω after multiplying **LRC** dials by **LRC** multiplier.

(9) Repeat technique of (6) through (8) above, using settings listed in table 4. TI Ω values will be within limits specified.

NOTE

For values above 1000 Ω , it is not necessary to subtract value obtained in (5) above.

b. Adjustments. No adjustments can be made.

Table 4. LRC Dial Multiplier Check

Resistance standard indications (Ω)	LRC dial multiplier switch settings (Ω)	Test instrument	
		Resistance (Ω) (LRC dials x LRC dial multiplier switch settings)	
		Min	Max
10	1	9.984	10.016
100	10	99.84	100.16
1,000	100	998.4	1,001.6
10,000	1 K	9,984	10,016
100,000	10 K	99,840	100,160
1,000,000	100 K	997,900	1,002,100

10. QX1 Rheostat

a. Performance Check

- (1) Disconnect TI from ac source and set **CIRCUIT SELECTOR** switch to **L** and **D-QX1**.
- (2) Remove shorting strap from **EXT D-Q** binding post.
- (3) Connect dc detector to resistance bridge (part of resistance measurement system), using straps supplied with dc detector.
- (4) Connect lead from resistance bridge **UNKNOWN 1** terminal to TI **EXT D-Q HI** terminal, and connect lead from resistance bridge **UNKNOWN 2** terminal to TI **C** (high) terminal.
- (5) Set the **Q** and **D-Q** dial to **6.3** on black scale.
- (6) Adjust resistance bridge for a null indication on dc detector. If resistance bridge does not indicate between 9930 and 10,130 Ω , perform **b**(1) through (4) below.
- (7) Set TI **CIRCUIT SELECTOR** switch to **L** and **QX100**.
- (8) Turn **Q** and **D-Q** dial to **6.3** on black scale.
- (9) Connect clip and cable from resistance bridge **UNKNOWN 1** terminal to center terminal of variable resistance R24 (fig. 1), and connect lead from resistance bridge **UNKNOWN 2** terminal to **EXT D-Q HI** binding post.

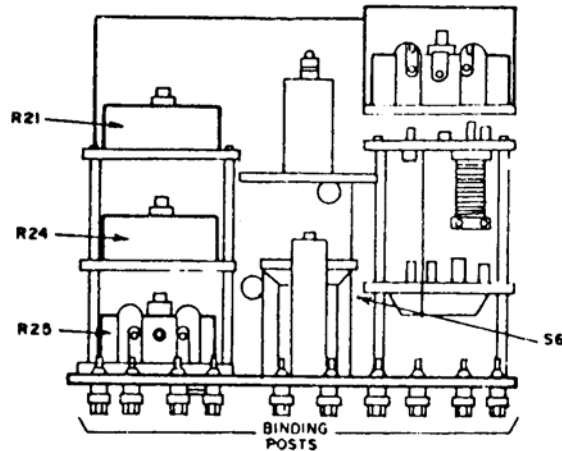

Figure 1. Capacitance, inductance, resistance adjustments.

- (10) Adjust resistance bridge for a null indication on dc detector. If resistance bridge does not indicate between 65 and 67 Ω , perform **b**(1), and (5) through (7) below.
- (11) Set **CIRCUIT SELECTOR** switch to **C** and **D-QX.01** position.
- (12) Adjust resistance bridge for a null indication on dc detector. Resistance bridge will indicate 99 to 101 Ω .
- (13) Set **CIRCUIT SELECTOR** switch to **C** and **D-QX.1** position.
- (14) Set **Q** and **D-Q** dial to **6.3** on black scale.

TB 9-6625-1014-35

(15) Connect lead from resistance bridge **UNKNOWN 1** terminal to center terminal of R24 and connect lead from resistance bridge **UNKNOWN 2** terminal to the center terminal of R21 (fig. 1).

(16) Adjust resistance bridge for a null indication on dc detector. If resistance bridge does not indicate between 993 and 1013 Ω , perform **b(8)** through (10) below.

(17) Replace shorting strap removed in (2) above and connect TI to ac source and energize.

b. Adjustments

(1) Remove bridge chassis from case.

(2) Loosen set screws in collar of contact and collar assembly for R25 (fig. 1).

(3) Rotate contact arm along the winding until resistance bridge indicates a null of 10,030 Ω .

(4) Tighten the two set screws in contact and collar assembly of R25 (fig. 1) (R).

(5) Loosen the two set screws in the collar of contact and collar assembly for R24 (fig. 1)

(6) Rotate contact arm along winding until resistance bridge indicates a null of 66 Ω .

(7) Tighten the two set screws in the contact and collar assembly of R24 (fig. 1) (R).

(8) Loosen the two set screws in the collar of contact and collar assembly for R21 (fig. 1)

(9) Rotate contact arm along resistance winding until resistance bridge indicates a null of 1003 Ω .

(10) Tighten the two screws in contact and collar assembly of R21 (fig. 1) (R).

(11) Replace bridge chassis in case.

11. Oscillator

a. Performance Check

(1) Connect equipment as shown in figure 2.

(2) Position controls as listed in (a) through (h) below:

(a) **CIRCUIT SELECTOR** switch to **L-D-QX-100H**.

(b) **LRC DIAL MULTIPLIER** switch to **L-100H**.

(c) **D-Q** dial (outer, black scale) to **10**.

(d) **DETECTOR** switch to **INTERNAL**.

(e) **GENERATOR** switch to **INTERNAL**.

(f) **OSC GAIN** control fully cw.

(g) Shorting bar connected to **EXT D-Q** binding posts.

(h) Adjust **LRC** outer dial off of **0**.

(3) Frequency counter will indicate between 990 and 1010 Hz, and multimeter will indicate at least 12 V ac.

(4) Adjust autotransformer output from 105 to 125 V ac, while observing frequency counter. Indicated frequency will remain between 990 and 1010 Hz.

(5) Adjust autotransformer output to 115 V ac.

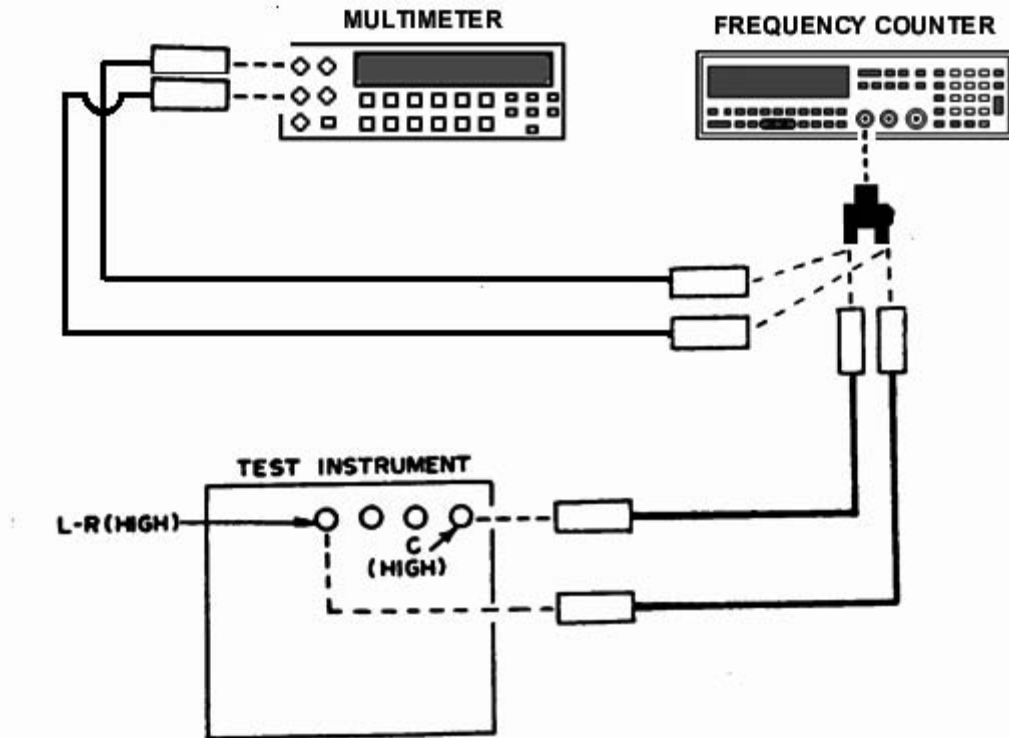

Figure 2. Oscillator - equipment setup.

b. Adjustments. No adjustments can be made.

12. Capacitance

a. Performance Check

- (1) Connect 0.1 μF capacitance standard to C binding posts.
- (2) Position controls as listed in (a) through (f) below:
 - (a) **CIRCUIT SELECTOR** switch to **D-QX.01**.
 - (b) **AMP RESPONSE** switch to **PEAK**.
 - (c) **DETECTOR** switch to **INTERNAL**.
 - (d) **GENERATOR** switch to **INTERNAL**.
 - (e) **LRC dial MULTIPLIER** switch to **.01 μF** .
 - (f) **LRC DIAL** to **10.00**.

TB 9-6625-1014-35

(3) Adjust TI **LRC** dial **AMP GAIN**, **OSC GAIN**, **Q** and **D-Q** dial for best null on electron ray tube. If capacitance standard is not furnished with a test report, final **LRC** dial setting will be between 9.949 and 10.051. If capacitance standard is furnished with test report, measured value will be within ± 0.5 percent + 1 division on **LRC** inner dial of test report value.

b. Adjustments. No adjustments can be made.

13. Final Procedure

a. Deenergize and disconnect all equipment.

b. Annotate and affix DA label/form in accordance with TB 750-25.

SECTION IV CALIBRATION PROCESS FOR ESI, MODEL 250DE

14. Preliminary instructions

a. The instructions outlined in paragraphs **14** and **15** are preparatory to the calibration process. Personnel should become familiar with the entire bulletin before beginning the calibration.

b. Items of equipment used in this procedure are referenced within the text by common name as listed in table 2.

c. Unless otherwise specified, verify the result of each test and, whenever the test requirement is not met, take corrective action before continuing with the calibration. Adjustments required to calibrate the TI are included in this procedure. Additional maintenance information is contained in the manufacturer's manual for this TI.

d. Unless otherwise specified, all controls and control settings refer to the TI.

15. Equipment Setup

WARNING

HIGH VOLTAGE is used or exposed during the performance of this calibration. DEATH ON CONTACT may result if personnel fail to observe safety precautions. REDUCE OUTPUT(S) to minimum after each step within the performance check where applicable.

NOTE

Some TI's are operated by 115 V ac and some are battery operated. Make power connections accordingly.

a. Connect TI to autotransformer and connect autotransformer to a 115 V ac source.

b. Turn **DET GAIN** control cw out of **PWR OFF** position.

c. Set **GEN DET** switch to **DC DET-DC EXT GEN**.

d. Adjust TI mechanical zero indication on meter.

16. LRC Dials

a. Performance Check

(1) Position TI controls as listed in (a) through (d) below:

- (a) **FUNCTION** switch to **RX10**.
- (b) **GEN-DET** switch to **BATT-TEST**.
- (c) **DET GAIN** control to **PWR OFF**.
- (d) **LRC** controls to **0000**.

(2) Connect leads from resistance bridge (part of resistance measurement system), **UNKNOWN 1** terminal to TI **EXT D-Q 1** terminal, and from **UNKNOWN 2** terminal to TI **RL 1** terminal.

(3) Adjust resistance bridge to obtain the best null indication on dc detector. Record resistance value.

(4) Set **LRC** dials to **0.020**.

(5) Adjust resistance bridge for null indication on dc detector.

(6) Subtract resistance value recorded in (3) above from value obtained in (5) above; difference will be between 19 and 21 Ω .

(7) Repeat technique of (4) through (6) above for remaining **LRC** dial settings listed in table 5. Resistance bridge will indicate within computed limits specified.

b. Adjustments. No adjustments can be made.

Table 5. **LRC** Dials Resistance Values

Test instrument LRC dials	Resistance standard indications	Computed difference	
		Min	Max
0.040	40	39	41
0.060	60	59	61
0.080	80	79	81
0.0X (100)	100	99	101
0.100	100	99.95	100.05
0.200	200	199.90	200.10
0.300	300	299.85	300.15
0.400	400	399.80	400.20
0.500	500	499.75	500.25
0.600	600	599.70	600.30
0.700	700	699.65	700.35
0.800	800	799.60	800.40
0.900	900	899.55	900.45
0.X	1000	999.50	1000.50
1.000	1000	999.5	1000.5
2.000	2000	1999.0	2001.0
3.000	3000	2998.5	3001.5
4.000	4000	3998.0	4002.0
5.000	5000	4997.5	5002.5

Table 5. LRC Dials Resistance Values - Continued

Test instrument LRC dials	Resistance standard indications	Computed difference	
		Min	Max
6.000	6000	5997.0	6003.0
7.000	7000	6996.5	7003.5
8.000	8000	7996.0	8004.0
9.000	9000	8995.5	9004.5
10.000	10000	9995.0	10,005.0
11.000	11000	10,994.5	11,005.5

17. QX1 Rheostat

a. Performance Check

- (1) Position controls as listed in (a) through (d) below:
 - (a) **FUNCTION** switch to **L-QX1 SERIES**.
 - (b) **DET GAIN** control to **OFF**.
 - (c) **GEN-DET** switch to **BATT TEST**.
 - (d) **EXT D-Q** terminals shorting strap removed.
- (2) Connect lead from resistance bridge **UNKNOWN 1** terminal to **EXT D-Q 2** terminal and connect lead from resistance bridge (part of resistance measurement system), **UNKNOWN 2** terminal to **TI C3** terminal.
- (3) Set **TI D-Q SERIES** dial to **2**.
- (4) Adjust resistance bridge for a null indication on dc detector (part of resistance measuring system).
- (5) If resistance bridge does not indicate between 2992 and 3375 Ω , perform **b** below.
- (6) Repeat technique of (3) through (5) above for **D-Q SERIES** dial settings listed in table 6. If resistance bridge does not indicate within limits specified, and adjustment was not required in (5) above, perform **b** below.
- (7) Replace shorting strap between **EXT D-Q** terminals.

b. Adjustments

- (1) Set resistance bridge control to 3184 Ω .
- (2) Adjust **D-Q SERIES** dial for null indication on dc detector.
- (3) Loosen setscrew on **D-Q SERIES** dial and, while maintaining a null dc detector, set dial to indicate 2. Tighten setscrew.
- (4) Repeat **a** (6) above.

Table 6. QX1 Rheostat Accuracy

Test instrument D-Q SERIES dial settings	Resistance standard initial settings	Resistance bridge indications (part of resistance measurement system) (Ω)	
		Min	Max
4	6320	6151	6597
6	9650	9295	9805
8	12,727	12,444	13,017
10	16,000	15,601	16,238

18. Resistance

a. Performance Check

(1) Certify resistance standard values with leads at 1, 10 and 100 Ω ; 1, 10, and 100 k Ω ; and 1 M Ω settings respectively using resistance bridge and dc detector (part of resistance measurement system). Record each value to 100 ppm.

(2) Set **RANGE** switch to **RX0.1 Ω** and **FUNCTION** switch to **RX1**.

(3) Set **GEN-DET** switch to **INT-DC** and **DET-GAIN** control to **2**.

(4) Connect equipment as shown in figure 3.

(5) Adjust resistance standard to 1.00 Ω .

(6) Adjust **LRC DIALS** until dc detector indicates null.

(7) TI dials will indicate within ± 1 percent plus one dial division of certified value recorded in (1) above.

(8) Repeat technique of (5) through (7) above for **RANGE** switch settings of **RX1**, **10**, **100**, **1K**, **10K**, and **100K**, with resistance standard set to 10 and 100 Ω ; 1, 10, and 100 k Ω ; and 1 M Ω , respectively.

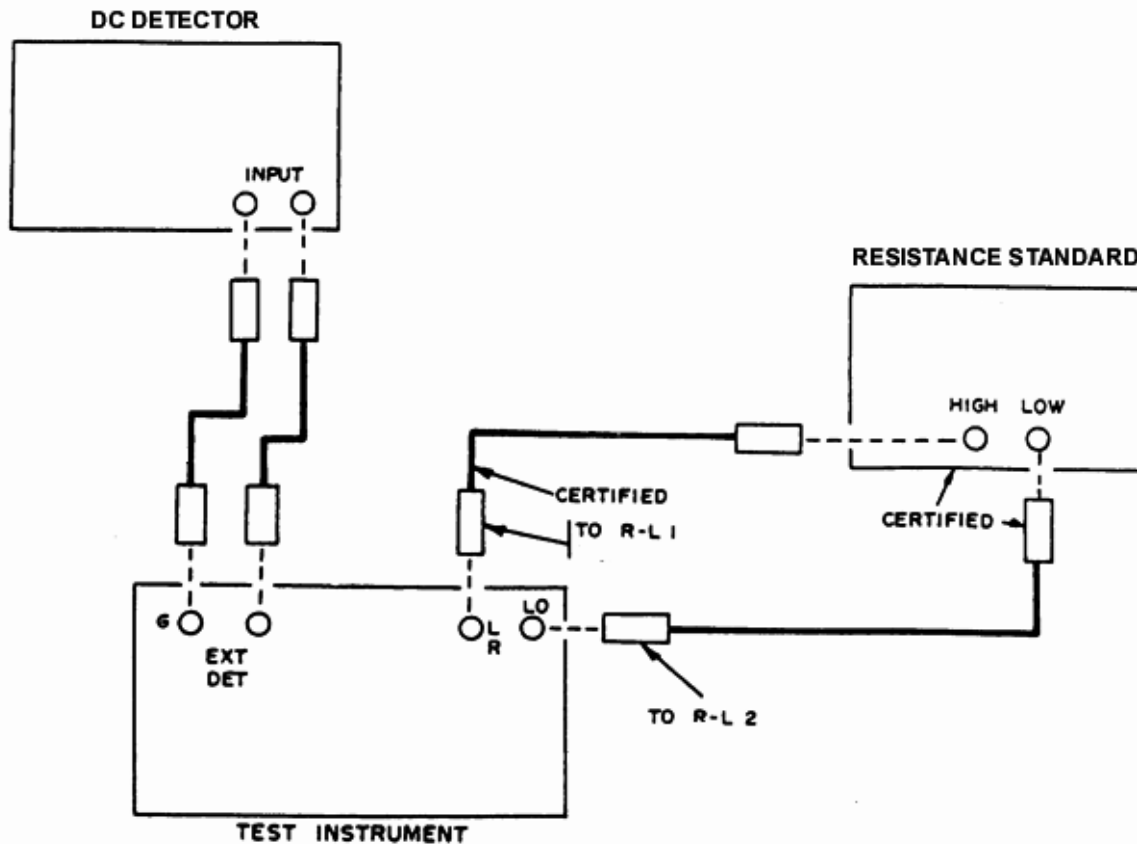

Figure 3. Resistance - equipment setup.

TB 9-6625-1014-35

- (9) Set **RANGE** switch to **RX100Ω** and **FUNCTION** switch to **RX 10**.
- (10) Adjust resistance standard for 10 kΩ.
- (11) Adjust TI **LRC** dials until dc detector indicates null.
- (12) TI dials will indicate within ± 1 percent plus one dial division of certified value recorded in (1) above.

b. Adjustments. No adjustments can be made.

19. Oscillator

a. Performance Check

- (1) Adjust TI **DET GAIN** control cw from **PWR OFF** position and **GEN DET** switch **AC DET INT 1 KHz**.
- (2) Connect frequency counter to TI **R-L1** (high) terminal and **EXT BIAS 1** (low) terminal. Frequency counter will indicate between 990 and 1010 Hz.

b. Adjustments. No adjustments can be made.

20. Capacitance

a. Performance Check

- (1) Position TI controls as listed in (a) through (c) below:
 - (a) **FUNCTION** switch to **CDx0.01 SERIES**.
 - (b) **D-Q SERIES** dial to **0**.
 - (c) **RANGE** switch to **Cx0.01 μF**.
- (2) Insert capacitance standard into 2C and 3C terminals.
- (3) Adjust TI **LRC** dial, **D-Q SERIES** dial, and **DET GAIN** control to obtain best null indication on TI meter.
- (4) If **LRC** dials do not indicate within ± 0.2 percent plus (+) one dial division of certified value of standard capacitor, perform b below.

b. Adjustments

- (1) Remove TI from case.
- (2) Set **RANGE** switch to **0.1 μF**.
- (3) Set TI **LRC** dials to **1.000**.
- (4) Adjust **D-Q** dials and trim capacitor C1 (attached to capacitance standard located above the transformer) alternately until null is obtained on meter (R).
- (5) Install TI in its case.

21. Dissipation

a. Performance Check

- (1) Connect equipment as shown in figure 4.
- (2) Adjust resistance standard to 31.85 Ω.

(3) Adjust TI **LRC** dial, **D-Q SERIES** dial, and **DET GAIN** control for best null indication on meter. **D-Q SERIES** - dial will indicate between 1.88 and 2.12.

(4) Repeat technique of (2) and (3) above, using resistance standard settings listed in table 7. **D-Q SERIES** dial will indicate within limits specified.

Table 7. Low Dissipation Accuracy

Resistance standard settings (Ω)	Test instrument D-Q SERIES dial indications	
	Min	Max
63.70	3.86	4.14
94.54	5.84	6.16
127.39	7.82	8.18
143.32	8.81	9.19

(5) Set **FUNCTION** switch to **CDx0.1 SERIES**.

(6) Adjust resistance standard to 318.48 Ω .

(7) Adjust **LRC** dial **D-Q SERIES** dial, and **DET GAIN** control for best null indication on meter. **D-Q SERIES** dial will indicate between 1.88 and 2.12.

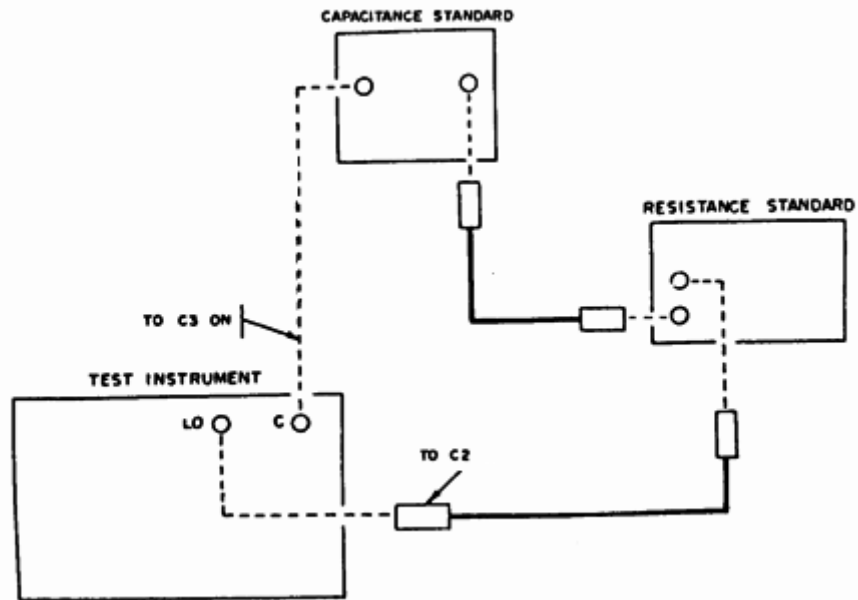

Figure 4. Dissipation - equipment setup.

(8) Repeat technique of (6) and (7) above, using resistance standard settings listed in table 8. **D-Q SERIES** dial will indicate within limits specified.

b. Adjustments. No adjustments can be made.

TB 9-6625-1014-35

Table 8. High Dissipation Accuracy

Resistance standard settings (Ω)	Test instrument D-Q SERIES dial indications	
	Min	Max
636.96	3.86	4.14
955.44	5.84	6.16
1273.92	7.82	8.18
1433.16	8.81	9.19

22. Final Procedure

- a. Deenergize and disconnect all equipment.
- b. Annotate and affix DA label/form in accordance with TB 750-25.

By Order of the Secretary of the Army:

Official

SANDRA R. RILEY
*Administrative Assistant to the
Secretary of the Army*

0515702

PETER J. SCHOOMAKER
*General, United States Army
Chief of Staff*

Distribution:

To be distributed in accordance with the initial distribution number (IDN) 342114,
requirements for calibration procedure TB 9-6625-1014-35.

Instructions for Submitting an Electronic 2028

The following format must be used if submitting an electronic 2028. The subject line must be exactly the same and all fields must be included; however, only the following fields are mandatory: 1, 3, 4, 5, 6, 7, 8, 9, 10, 13, 15, 16, 17, and 27.

From: "Whomever" whomever@redstone.army.mil
To: <2028@redstone.army.mil

Subject: DA Form 2028

1. **From:** Joe Smith
2. **Unit:** home
3. **Address:** 4300 Park
4. **City:** Hometown
5. **St:** MO
6. **Zip:** 77777
7. **Date Sent:** 19-OCT -93
8. **Pub no:** 55-2840-229-23
9. **Pub Title:** TM
10. **Publication Date:** 04-JUL-85
11. **Change Number:** 7
12. **Submitter Rank:** MSG
13. **Submitter FName:** Joe
14. **Submitter MName:** T
15. **Submitter LName:** Smith
16. **Submitter Phone:** 123-123-1234
17. **Problem:** 1
18. **Page:** 2
19. **Paragraph:** 3
20. **Line:** 4
21. **NSN:** 5
22. **Reference:** 6
23. **Figure:** 7
24. **Table:** 8
25. **Item:** 9
26. **Total:** 123
27. **Text**

This is the text for the problem below line 27.

